

## STANDBY SERIES SP12-33(12V33AH/10HR)

### Specifications

Nominal Voltage	12V	
Nominal Capacity(10hr)	33AH	
Dimension	Length	196±2mm(7.72inch)
	Width	133±2mm(5.24inch)
	Height	169±2mm(6.65inch)
	Total Height	170±2mm(6.69inch)
Approx Weight	Approx. 10.6kg(+/-4%)	
Terminal Type	M6	
container Material	ABS(UL-94HB)	
Internal Resistance	Approx.10.0mΩ	
Rated Capacity	34.0AH	(20hr, 1.70V/cell,25°C/77°F)
	33.0AH	(10hr, 1.75V/cell,25°C/77°F)
	30.0AH	(5hr, 1.75V/cell,25°C/77°F)
	23.0AH	(3hr, 1.70V/cell,25°C/77°F)
	19.0AH	(1hr, 1.60V/cell,25°C/77°F)
Max. Discharge Current	330A(5S)	
Nominal Operating Temp. Range	25±3°C (77±5°F)	
Cycle Use	Charge Current Less Than 0.25CA	
	14.1V~14.7V@25°C(77°F)Temp. Coefficient -30mV/°C	
Floating Use	13.5V~13.8V@25°C(77°F)Temp. Coefficient -20mV/°C	
Capacity affected by Temperature	40°C	103%
	25°C	100%
	0°C	86%
	-15°C	65%
Self-discharge	3 month	Remaining capacity: 91%
	6 month	Remaining capacity:82%
	12month	Remaining capacity:65%



### Dimensions

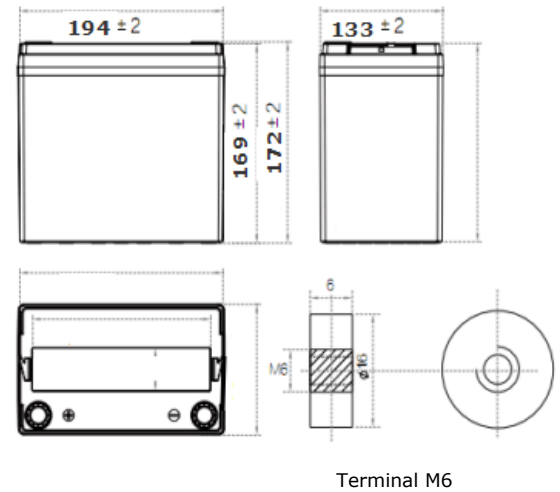

### Constant Power Discharge at 25°C(77°F)

F.V/Time	5min	10min	15min	30min	1h	2h	3h	4h	5h	6h	10h	20h
1.80V/cell	170	150	110	69,2	36,8	21,5	17,3	13,6	11,1	9,5	6,49	3,27
1.75V/cell	173	152	111	69,7	38,6	22,0	17,4	13,7	11,2	9,5	6,50	3,28
1.70V/cell	185	155	113	70,8	39,8	22,6	17,7	13,8	11,3	9,6	6,50	3,29
1.67V/cell	188	157	119	71,4	40,6	23,1	17,8	13,8	11,4	9,7	6,51	3,30
1.60V/cell	190	168	124	72,0	41,1	23,6	17,9	13,9	11,5	10	6,52	3,30

### Constant Current Discharge at 25°C(77°F)

F.V/Time	5min	10min	15min	30min	1h	2h	3h	4h	5h	6h	10h	20h
1.80V/cell	86,5	76,3	55,9	35,1	18,7	10,9	8,8	6,91	5,63	4,80	3,29	1,66
1.75V/cell	87,7	77,1	56,4	35,4	19,6	11,2	8,8	6,96	5,67	4,82	3,30	1,67
1.70V/cell	94,0	78,8	57,5	35,9	20,2	11,4	9,0	7,02	5,73	4,87	3,30	1,67
1.67V/cell	95	79,9	60,3	36,2	20,6	11,7	9,1	7,03	5,78	4,94	3,31	1,67
1.60V/cell	97	85,4	63,0	36,5	20,8	12,0	9,1	7,04	5,83	4,98	3,31	1,68

# STANDBY SERIES SP12-33(12V33AH/10HR)

## Discharge Characteristics

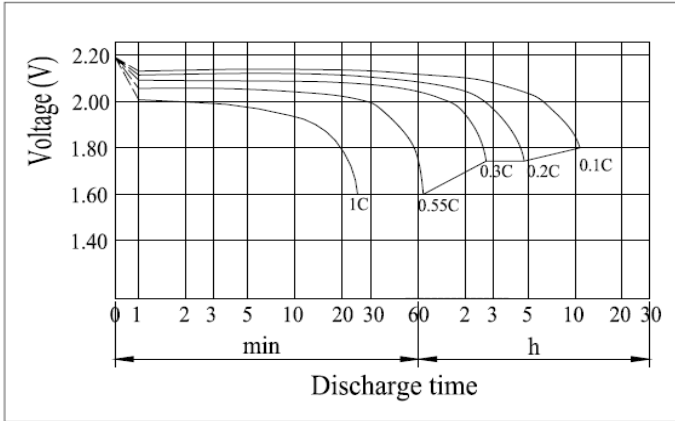

## Float Charging Characteristics

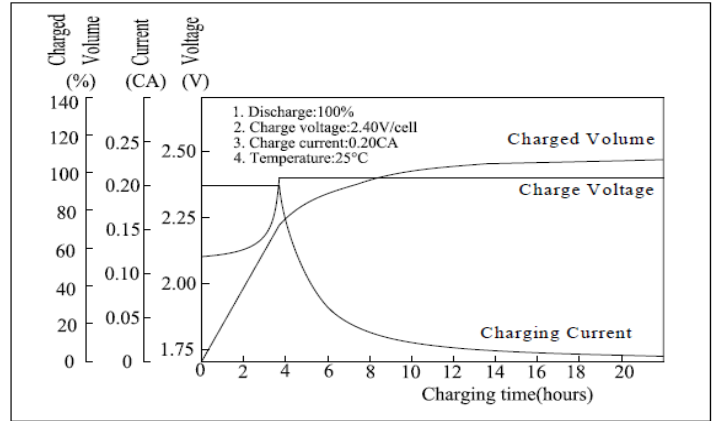

## Floating Life on Temperature

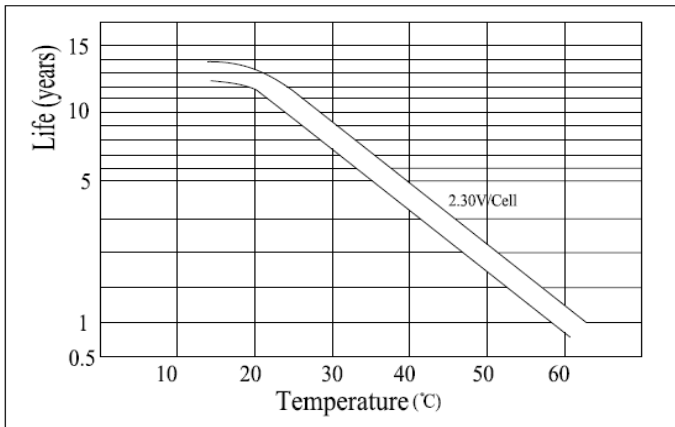

## Self Discharge Characteristics ( 25°C(77°F) )

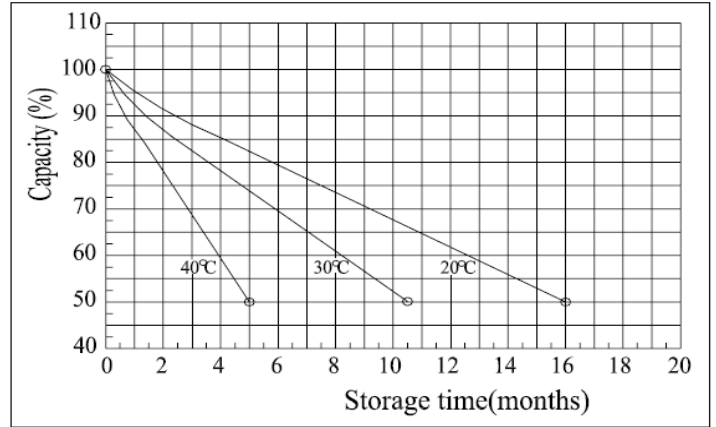

## Temperature Effects in Relation to Battery Capacity

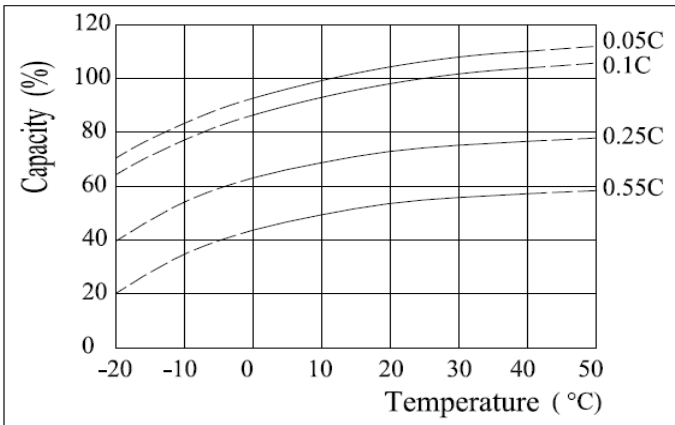

## Cycle Life Relation to Depth of Discharge

