

## STANDBY SERIES GFM-3000C(2V3000AH/10HR)

### Specifications

Nominal Voltage	2V	
Nominal Capacity(10hr)	3000AH	
Dimension	Length	710±2mm(27.95inch)
	Width	353±2mm(13.9inch)
	Height	345±2mm(13.58inch)
	Total Height	382±2mm(15.04inch)
Approx Weight	Approx.184.0kg(+/-4%)	
Terminal Type	M8	
container Material	ABS(UL94-V0)	
Internal Resistance	Approx.0.45mΩ	
Rated Capacity	3100AH	(20hr, 1.75V/cell,25°C/77°F)
	3000AH	(10hr, 1.75V/cell,25°C/77°F)
	2525AH	(5hr, 1.75V/cell,25°C/77°F)
	2220AH	(3hr, 1.75V/cell,25°C/77°F)
	1650AH	(1hr, 1.75V/cell,25°C/77°F)
Max. Discharge Current	7200A(5S)	
Nominal Operating Temp. Range	25±3°C (77±5°F)	
Cycle Use	Charge Current Less Than 0.25CA	
	2.35V~2.45@25°C(77°F)Temp. Coefficient -30mV/°C	
Floating Use	No limit on Initial Charging Current Voltage	
	2.25V~2.30V@25°C(77°F)Temp. Coefficient -20mV/°C	
Capacity affected by Temperature	40°C	103%
	25°C	100%
	0°C	86%
	-15°C	65%
Self-discharge	3 month	Remaining capacity: 91%
	6 month	Remaining capacity:82%
	12month	Remaining capacity:65%



### Dimensions

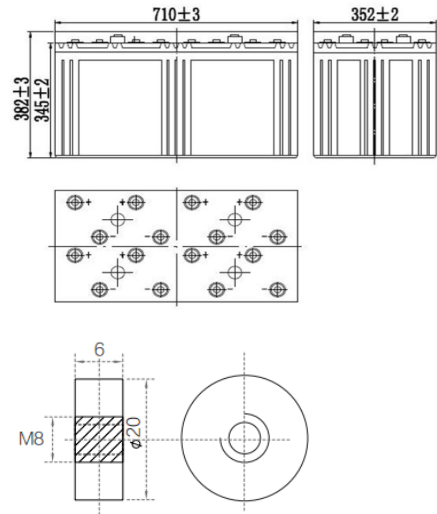

### Constant Power Discharge at 25°C(77°F)

F.V/Time	10min	15min	30min	1h	2h	3h	4h	5h	6h	8h	10h	20h
1.85V/cell	6946	6117	4465	3001	2025	1531	1153	1034	829	734	599	311
1.80V/cell	7369	6437	4602	3088	2083	1607	1205	1080	870	768	609	314
1.75V/cell	7873	6643	4728	3346	2127	1638	1223	1099	886	781	615	316
1.70V/cell	8214	7017	4808	3518	2171	1668	1239	1114	900	788	622	323
1.67V/cell	8782	7139	4945	3590	2200	1699	1270	1118	911	792	628	326
1.60V/cell	8989	7308	5094	3633	2258	1714	1301	1122	918	794	638	328

### Constant Current Discharge at 25°C(77°F)

F.V/Time	10min	15min	30min	1h	2h	3h	4h	5h	6h	8h	10h	20h
1.85V/cell	3709	3027	2265	1416	913	713	560	482	393	336	297	153
1.80V/cell	4144	3282	2496	1485	949	726	573	493	404	342	299	154
1.75V/cell	4519	3506	2588	1554	985	739	585	505	415	348	301	155
1.70V/cell	4935	3644	2742	1603	1024	760	602	518	423	354	302	157
1.67V/cell	5320	3819	2881	1712	1053	793	623	533	433	360	303	158
1.60V/cell	5610	4057	3023	1773	1088	817	642	551	443	363	303	160

# STANDBY SERIES GFM-3000C(2V3000AH/10HR)

## Discharge Characteristics

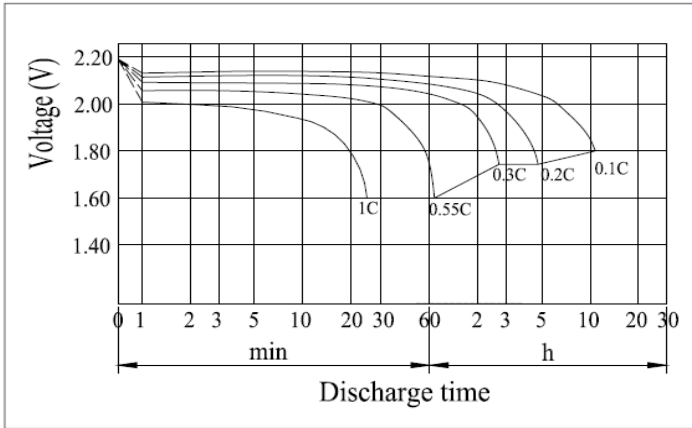

## Float Charging Characteristics

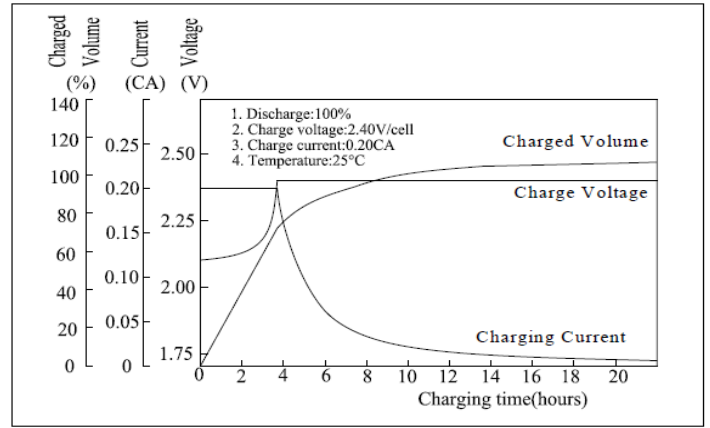

## Floating Life on Temperature

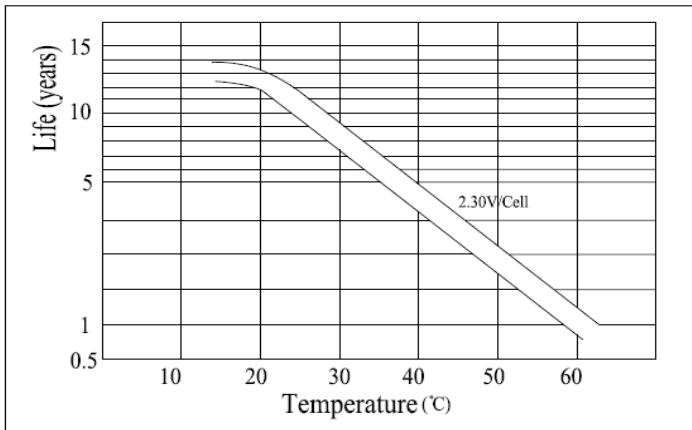

## Self Discharge Characteristics ( 25°C(77°F) )

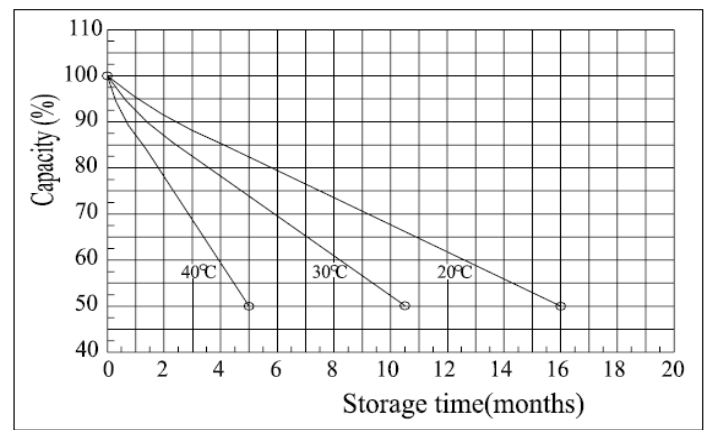

## Temperature Effects in Relation to Battery Capacity

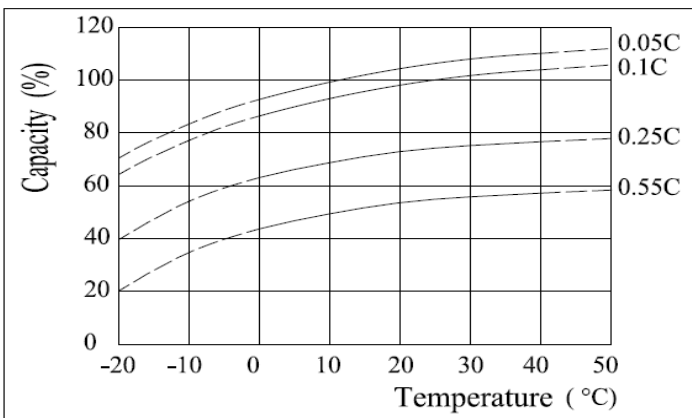

## Cycle Life Relation to Depth of Discharge

