

STANDBY SERIES GFM-1000C(2V1000AH/10HR)

Specifications

Nominal Voltage	2V	
Nominal Capacity(10hr)	1000AH	
Dimension	Length	475±2mm(18.66inch)
	Width	175±2mm(6.81inch)
	Height	330±2mm(12.95inch)
	Total Height	367±2mm(14.41inch)
Approx Weight	Approx. 59kg(+/-4%)	
Terminal Type	M8	
container Material	ABS(UL-94HB)	
Internal Resistance	Approx.0.4mΩ	
Rated Capacity	1050.0AH	(20hr, 1.70V/cell,25°C/77°F)
	1000.0AH	(10hr, 1.75V/cell,25°C/77°F)
	880.0AH	(5hr, 1.75V/cell,25°C/77°F)
	750.0AH	(3hr, 1.70V/cell,25°C/77°F)
	250.0AH	(1hr, 1.60V/cell,25°C/77°F)
Max. Discharge Current	8000A(5S)	
Nominal Operating Temp. Range	25±3°C (77±5°F)	
Cycle Use	Charge Current Less Than 0.25CA	
	2.35V~2.45@25°C(77°F)Temp. Coefficient -30mV/°C	
Floating Use	No limit on Initial Charging Current Voltage	
	2.25V~2.30V@25°C(77°F)Temp. Coefficient -20mV/°C	
Capacity affected by Temperature	40°C	103%
	25°C	100%
	0°C	86%
	-15°C	65%
Self-discharge	3 month	Remaining capacity: 91%
	6 month	Remaining capacity:82%
	12month	Remaining capacity: 65%



Dimensions

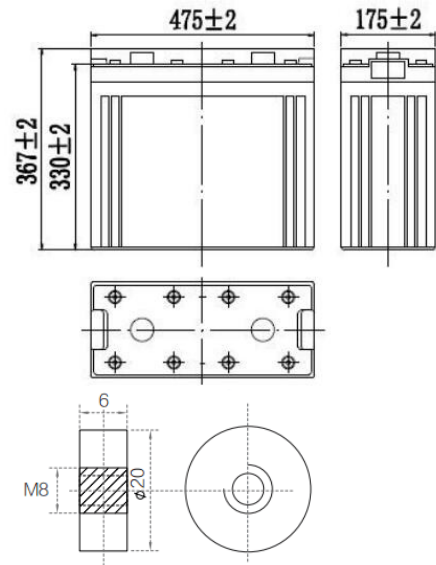

Constant Power Discharge at 25°C(77°F)

F.V/Time	10min	15min	30min	1h	2h	3h	4h	5h	6h	8h	10h	20h
1.85V/cell	2291	2126	1565	947	631	453	346	302	254	213	182	100
1.80V/cell	2539	2295	1614	974	648	475	367	316	270	222	185	101
1.75V/cell	2869	2356	1657	1055	661	485	375	321	275	226	187	101
1.70V/cell	3058	2508	1685	1109	674	494	380	326	280	229	188	103
1.67V/cell	3269	2596	1735	1131	685	504	389	326	283	230	192	104
1.60V/cell	3346	2731	1786	1147	702	508	399	327	284	230	193	105

Constant Current Discharge at 25°C(77°F)

F.V/Time	10min	15min	30min	1h	2h	3h	4h	5h	6h	8h	10h	20h
1.85V/cell	1352	1107	796	454	283	226	183	148	128	108	98	51
1.80V/cell	1481	1179	839	475	295	230	187	149	132	110	99	52
1.75V/cell	1550	1220	867	499	307	235	191	150	135	112	100	52
1.70V/cell	1658	1253	950	515	319	241	195	151	138	114	101	53
1.67V/cell	1739	1349	991	531	327	251	203	152	141	116	103	53
1.60V/cell	1827	1403	1028	550	338	259	208	153	144	117	105	55

STANDBY SERIES GFM-1000C(2V1000AH/10HR)

Discharge Characteristics

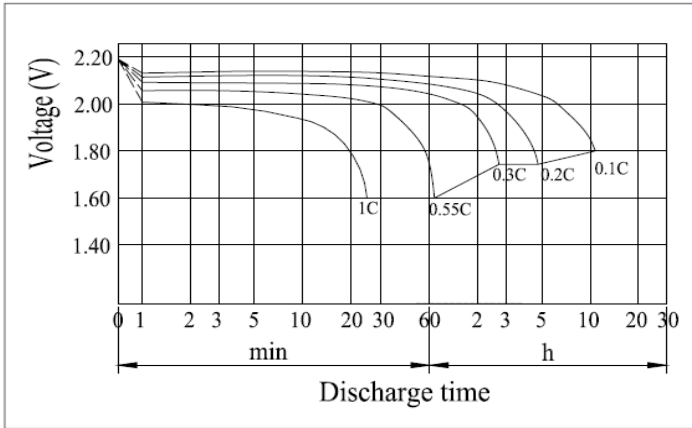

Float Charging Characteristics

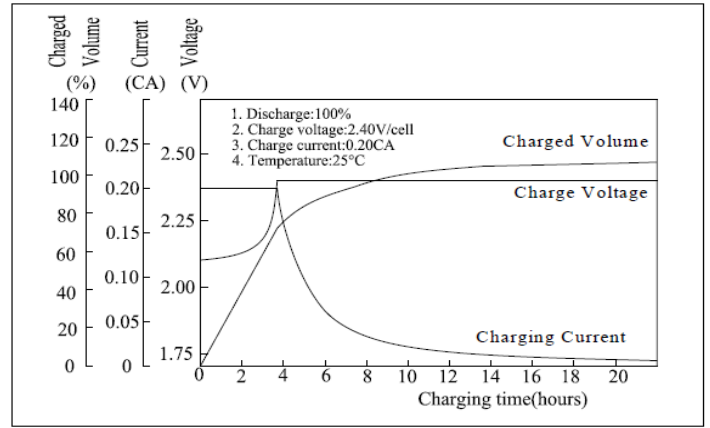

Floating Life on Temperature

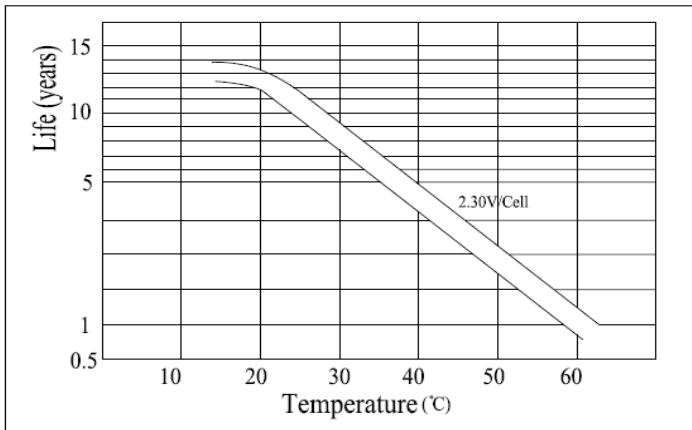

Self Discharge Characteristics (25°C(77°F))

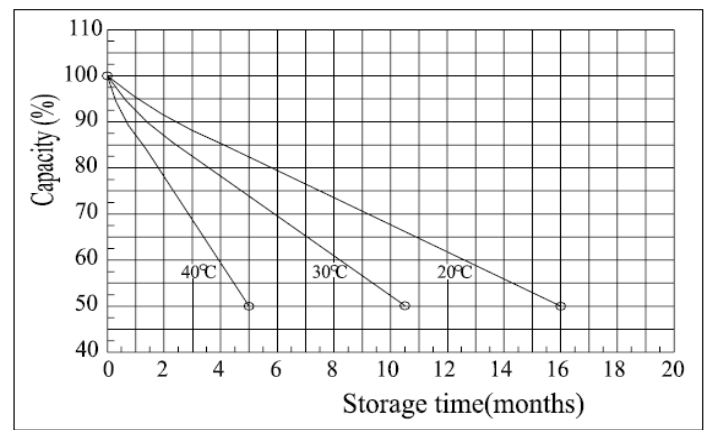

Temperature Effects in Relation to Battery Capacity

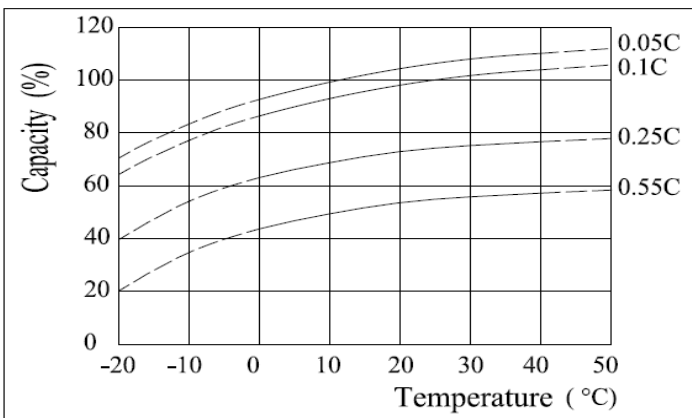

Cycle Life Relation to Depth of Discharge

